

Tutti i marchi, i nomi e i modelli di telefono cellulare sono di proprietà dei rispettivi titolari.

All trademarks, names and mobile phone models are the property of the respective companies.

ISTRSMCRAB

**cellularline**  
INTERPHONE

Distribuito da: / Distributed by:  
CELLULARLINE S.p.A.  
via Lambrakis 1/A  
42122 Reggio Emilia - Italy  
[www.interphone.com](http://www.interphone.com)  
[www.cellularline.com](http://www.cellularline.com)

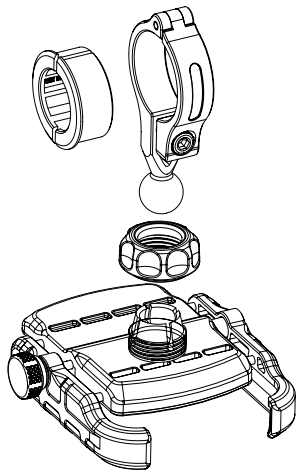

Povolte objímku, zafixujte kuličku do podložky a objímku znovu utáhněte a zajistěte.

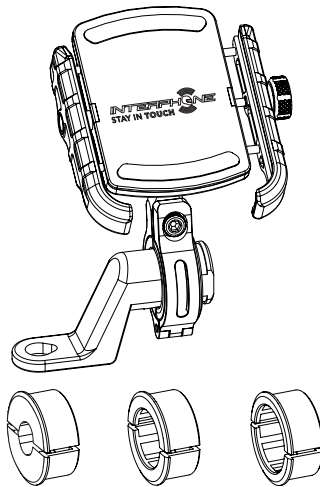

Kompatibilní s řídky o průměru 12 – 32 mm, v případě nutnosti použijte distanční podložky.



**Návod na použití**

INTERPHONE  
STAY IN TOUCH

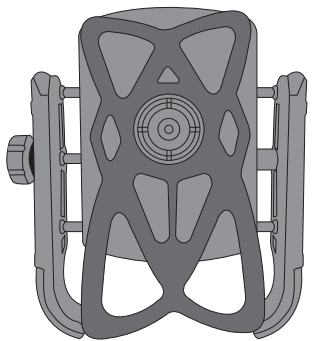

Elastickou pojistku uchyťte dle nákresu.

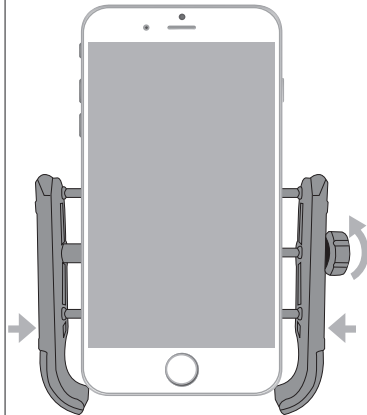

Vložte telefon do držáku a zajistěte nastavitelné kleště.

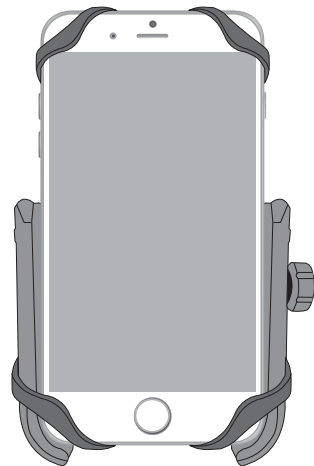

Zajistěte telefon elastickou pojistkou dle nákresu.

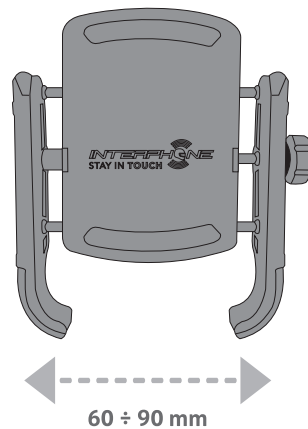

Maximální a minimální šířka.